

CHAPTER 4

The Mechanistic Bases of Behavioral Evolution: A Multivariate Analysis of Musculoskeletal Function

George V. Lauder and Stephen M. Reilly

Of the many approaches that one might take to studying animal behavior, the comparative and phylogenetic analysis of physiological traits has been one of the least utilized. On the one hand, the discipline of neuroethology has had spectacular success in investigating the neural basis of behavior in individual species, but only rarely have such studies ventured into phylogenetic territory (e.g., Arbas et al. 1991; Hoy et al. 1988; Katz 1991). For the most part, neuroethologists have focused on understanding the mechanistic basis of behavior in individual species and on clarifying the motor and sensory systems involved in generating behavior. However, some evolutionary biologists have used physiological and neural traits to understand evolutionary processes such as sexual selection and mate choice (Ryan & Keddyhector 1992; Ryan & Rand 1990).

On the other hand, comparative biologists have recently taken increased interest in studying behavioral evolution. Behavioral characters are again being used to generate phylogenies (De Queiroz & Wimberger 1993; Wenzel 1992), a return to earlier days in ethology when the phylogenetic study of behavior was common (Lauder 1986; McLennan et al. 1988). Behavioral traits have also been correlated with

other characters such as body size, territory size, and brain size to clarify historical (phylogenetic) patterns of character coevolution (Brooks & McLennan 1991; Harvey & Keymer 1991; Harvey & Pagel 1991; Pagel & Harvey 1988), and many of these studies are using recently developed quantitative comparative methods (Felsenstein 1985; Garland et al. 1992, 1993; Grafen 1989; Harvey & Pagel 1991; Martins & Garland 1991). The central theme of Felsenstein's (1985) oft-cited paper, that species cannot be treated as statistically independent entities in comparative analysis due to their genealogical relationship to each other, has now permeated the comparative literature (e.g., Garland & Adolph 1994; Huey 1987; Miles & Dunham 1993).

However, only rarely have comparative analyses been extended to physiological traits that directly measure the function of phenotypic features. The relative lack of comparative analyses of physiological traits is understandable given that determining the value of physiological characters usually involves conducting laboratory experiments on multiple individuals in each of the taxa to be used in the phylogenetic analysis. Obtaining physiological or functional characters might involve using several different techniques to measure multiple traits, which greatly increases the effort needed to obtain comparative data. Furthermore, individuals in taxa critical for the phylogenetic analysis, such as outgroup clades, may not be readily available (or amenable) for laboratory study, making a complete phylogenetic analysis of physiological traits difficult.

Despite these difficulties, there is considerable value in analyzing physiological or functional traits that underlie behavior. First, there are few data on patterns of evolution in physiological or functional characters. Most comparative analyses are of structural, genetic (relying on DNA base or amino acid sequences), or behavioral data (Lauder 1990). Second, the analysis of physiological characters provides data on the proximate causes of behavior. For example, by studying the neuromuscular mechanisms that generate behavior in related species, we can understand the specific changes in neural activation and muscle physiology that cause novel behavior. Third, data on functional characteristics enable us to examine the relationship between form and function from a historical perspective. If we are to analyze the relationship between structure and function in a noncircular manner, then functional traits must not be inferred from structure but should be

measured independently (Lauder 1990, 1995; Reilly & Wainwright 1994). Applying comparative phylogenetic methods to structural and functional traits will then allow us to examine coevolutionary patterns to structural and functional characters, much as host-parasite coevolutionary patterns may be studied phylogenetically (e.g., Brooks & McLennan 1993; Mitter et al. 1991).

The major aims of this chapter are, first, to explain in more detail the value of a comparative examination of the physiological bases of behavior as a means to understanding how behavior evolves; second, to illustrate one approach to examining the relationship among different classes of functional traits as a heuristic tool to aid in understanding the mechanistic bases of behavioral evolution; third, to provide a case study of aquatic feeding behavior in salamanders as an example of the interspecific analysis of behavioral differentiation.

Physiological bases of behavioral evolution

A. Levels of analysis

A key concept for the comparative analysis of mechanistic bases of behavioral differentiation among species is the heuristic separation of underlying physiological mechanisms into several different levels. As illustrated in Table 4.1, a behavioral difference between two species could be due to changes at one or more of a number of levels. Behavior itself (row 1 in Table 4.1) could be quantified by measuring the amplitude and direction of movement, and/or velocities or accelerations of bones using a high-speed film or video system. If two species differ in behavior, in the movements of the forelimb during a mating display for example, the differences we observe might be due to changes in one or more structural and physiological properties (rows 2 through 5 in Table 4.1). Species may differ in the topological arrangement of muscles and bones of the limb or in structural properties of the muscles causing the movement (such as muscle fiber type). In addition, observed interspecific differences in behavior might be due to alterations in one or more species of the physiological properties of peripheral musculature, such as the contraction time. Changes in the central nervous system, either in structure (such as the pattern of neuronal

interconnection) or function (activation or modulation of neuronal circuits generating motor output) could also cause a novel behavior to be observed in one or more species. Table 4.1 certainly does not represent the only possible arrangement of causal levels; many other possible classes of traits could be chosen that might underlie behavioral variation. But whatever the specific levels or hierarchical organization chosen, some decomposition of causal mechanisms of behavior is likely to be a valuable heuristic for our attempts to understand behavioral evolution.

Table 4.1. Hierarchy of classes of data (characters or traits) that might be analyzed to understand the mechanistic bases of behavioral attributes.

Class of data	Example of an organismal trait that might be studied interspecifically
1. Behavioral	Pattern of forelimb movement during a mating display
2. Structural (at the level of peripheral tissues)	Topographic arrangement of muscles and bones; tissue histology; muscle fiber types
3. Functional/physiological (at the level of peripheral tissues)	Physiological properties of muscles; biomechanical tissue properties; pattern of muscle activation
4. Structural (at the level of the nervous system)	Neuronal morphology; topology of neuronal interconnection; wiring of sensory and motor pathways
5. Functional/physiological (at the level of the nervous system)	Neuronal spiking patterns; motor patterns; membrane properties; modulation by neurotransmitters

In this particular hierarchy, characters are grouped into either structural or functional/physiological classes to reflect potential proximate causes for variation at the behavioral level. Note that variation in a behavioral trait among species might be due to change at a number of possible levels. See also Fig. 1 for a schematic illustration of this idea.

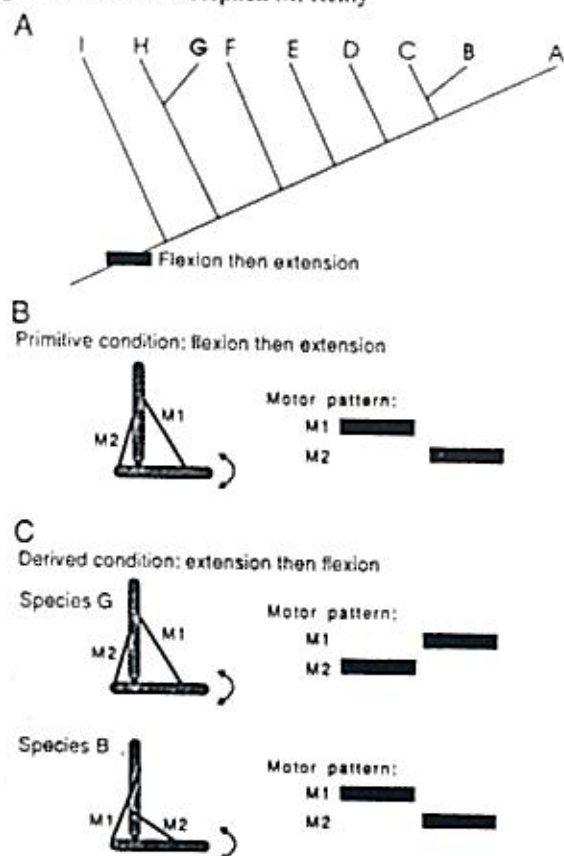

Figure 1. Schematic diagrams illustrating the role of different classes of characters in behavioral evolution. **A:** phylogenetic relationships of nine taxa. The ancestral condition for this clade is the behavior "flexion then extension" of the bony elements (shaded) shown in panel B. Taxa in bold (B and G) possess a derived behavior "extension then flexion" illustrated in panel C. **B:** morphological configuration of a limb in most taxa within the clade shown in panel A. Two muscles (M1 and M2) connect the bony elements that are attached at a joint (black dot). The pattern of muscle activation for these species is shown to the right. Black bars indicate the duration of muscle activity. Note that activation of M1 followed by M2 generates the behavior "flexion then extension." **C:** derived behavior, morphology, and motor pattern in species G and B. Both species convergently possess the derived behavior, but differ in the underlying mechanistic causes of the novel behavior. Species G retains the ancestral morphology for the clade but possesses a novel motor pattern. Species B exhibits a novel morphology (in which the muscles have changed their insertions) but retains the primitive motor pattern.

Figure 1 schematically illustrates how evolutionary changes at two of the levels discussed above might independently result in a novel behavior. A comparative behavioral investigation of the nine species in a clade (Fig. 1A) indicates that all taxa except B and G generate a threat behavior with the forelimb called "flexion followed by extension": the lower bone in Fig. 1B moves up in flexion, followed by a downward extension movement. Mapping this character onto the cladogram reveals that "flexion followed by extension" behavior is the ancestral condition for this clade. Further comparative investigation demonstrates that two species, B and G, possess a novel threat behavior that may be described as "extension followed by flexion." Within this clade these two species display convergently acquired behavioral novelties. How has this behavioral novelty been produced in these two species?

Investigation of the anatomy of species in this clade shows that all species possess a forelimb with a basic structure consisting of two bones connected at one joint which is spanned by two muscles (Fig. 1B), M1 and M2. However, in species B (and only in species B), M1 and M2 have changed position relative to the ancestral condition. An ontogenetic study shows that M1 grows posteriorly to attach behind the joint, while M2 grows anteriorly to insert anterior to the joint (Fig. 1C). This contrasts with the condition in all other species in which muscle M1 runs anteriorly to its attachment, while muscle M2 inserts posterior to the joint (Fig. 1B).

Measurement of the activation pattern of the two muscles in each species (by implanting small electrodes in the muscles and recording electromyograms during the threat behavior) reveals the motor pattern shown to the right of the morphology in panels B and C. In all species except species G, the motor activity pattern is that muscle M1 is activated first, followed by muscle M2. In species G, however, muscle M2 is activated first, followed by muscle M1. A simple biomechanical analysis confirms that given the morphology of the limb in species B, activating M1 causes extension of the horizontal bone, and that the subsequent activation of M2 causes flexion of that bone. In this species, then, the behavioral novelty ("extension followed by flexion") results from a topological rearrangement at the level of musculoskeletal structure and not from any change in neural output to the musculature. In fact, species B shares the ancestral motor pattern for the clade as a

whole. Recordings of the motor pattern in species G show a different result. Unique to all species in the clade, species G possesses a novel motor pattern in which muscle M2 is activated prior to muscle M1. Given the topology of the musculoskeletal system, such a motor pattern will produce a movement of "extension followed by flexion".

Even though the behavior might appear to be similar in species B and G, the underlying mechanistic bases of the behavior are different. The novel behavior in B resulted from changes at the level of peripheral gross morphology, while the novel behavior in species G resulted from evolution in the motor pattern. If we do not investigate the mechanistic basis of behavioral evolution, then we will be unable to focus on the appropriate hierarchical level at which behavioral novelty is generated (Lauder 1994).

One benefit to such a schema for considering behavioral evolution is the Newtonian mechanical basis for musculoskeletal and nervous function that permits increased confidence in attributions of cause and effect. If two taxa differ in behavior and motor pattern and yet are similar in morphology, a biomechanical analysis of the effects of those differences in motor pattern enables functional morphologists to predict differences in behavior. Behavioral differences are caused (in the mechanical sense) by novelties at some level (Table 4.1), and evolutionary patterns at each level may not be congruent. In our view, a key question in the analysis of behavioral evolution is the identification of the appropriate hierarchical level or levels that account causally for behavioral differences among species.

B. Visualizing multivariate levels

One limitation to the approach discussed above, of dissecting the causal basis of behavioral differences among species, is that too often such analyses are univariate in nature and focus on only a few variables. Yet all levels presented in Table 4.1, from behavior to neuronal physiology, are intrinsically multivariate; the analysis of many attributes of each level is necessary to adequately capture interspecific variation. Univariate approaches have been of considerable value in the past, used extensively in biomechanical analyses of musculoskeletal function where the influence of specific features of muscle structure and function on movement are of interest. In an example taken from our own work,

we analyzed the mechanism by which salamanders feeding on land project their tongues toward the prey during feeding (Reilly & Lauder 1991). We studied the effect of one muscle (the subarcualis rectus one, SAR1) on feeding performance and behavior. As this muscle was believed to provide the main motive force projecting the tongue from the mouth, our focus was on the effect of structure and function of the SAR1 on behavior.

However, in order to adequately describe interspecific variation in any class of traits, a multivariate approach allows many different measured attributes at each level to contribute to decisions as to which species differ from others. While use of multivariate analyses is hardly new in most areas of biology (Bookstein et al. 1985; Rohlf & Bookstein 1990), in the interspecific study of organismal function and physiology multivariate studies of variation are relatively rare.

One way in which we might extend the depiction of different mechanistic levels underlying behavior (Table 4.1) to a multivariate framework is to use a basic multivariate technique such as principal components analysis to describe variation at each level. For example, measurement of a variety of different aspects of movement of the hindlimb during locomotion (such as the amplitude of excursion of each of the bones in the limb and their peak velocities and accelerations) for several individuals in each species of a clade could be used to measure variation at the behavioral level. This would generate a data set of several kinematic variables for each species, and such a data set could be subjected to principal components analysis to summarize variation among the species.

A principal components analysis (PCA) generates a set of new variables that are linear combinations of the original variables in the data set. Coefficients of variables contributing to the first PC are chosen to maximize the variance for PC1, and PC1 thus represents the vector of greatest variation in the data set. PC2 is calculated similarly, but the PC scores calculated from the linear combination of variables and coefficients must be uncorrelated with the PC1 scores. The variation in the data set explained by PC2 is thus uncorrelated with that explained by PC1. The number of principal components calculated is equal to the number of original variables, with each successive component accounting for successively less variation; the first four PCs commonly

account for greater than 75% of variation in the data set. Useful descriptions of PCA are given in Duntzman (1989) and Harris (1975). An important use of PCA is to reduce a data set with a large number of intercorrelated variables to a smaller set of uncorrelated variables. Analyzing these uncorrelated PCs avoids the problem of interpreting separate univariate analyses that are correlated with each other in a complex fashion (Bray & Maxwell 1985; Willig et al. 1986). Multivariate variation in a large number of variables can be summarized succinctly. Each variable can also be examined for its contribution to the overall PC score on each component, so that the specific pattern of variation in measured variables can be determined.

Figure 2 illustrates schematically one possible result from such a PCA. Given five taxa (A to E), we could analyze behavioral variation by conducting a PCA on the set of kinematic variables and then plot the mean position of each species in the resulting multivariate space (Fig. 2B). Only principal components 1 and 2 are shown, as these represent the greatest percentage of variation within the data set. While the technique of principal components analysis itself does not account for phylogenetic relationships among species in calculating the component scores, these scores can be calculated using phylogenetically standardized contrasts of the original data matrix (if a corroborated phylogeny of the species is available, Felsenstein 1985). Martins (1993) provides an example of this procedure in an analysis of behavioral characters. In order to define differences among species, we could also analyze principal component scores to test for significant groupings among the taxa. Figure 2B also illustrates an example of a multivariate analysis of variance on the principal component scores (accounting for individuals within each taxon). Taxa A and B are not significantly different in behavior from each other (and are thus grouped by a circle), while these two taxa together do occupy a significantly different portion of the behavioral space from taxa C, D, and E, all of which are behaviorally distinct from each other as well as from taxa A and B together.

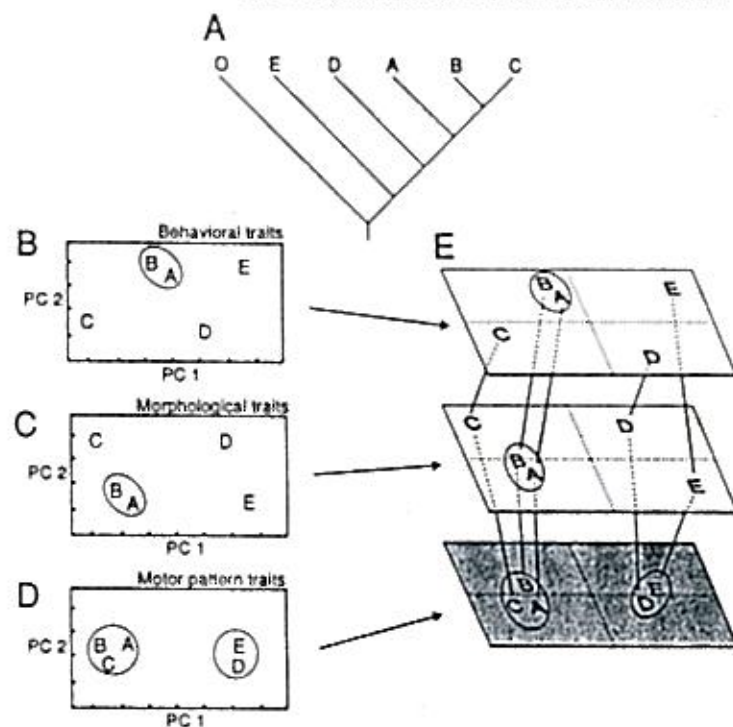

Figure 2. Schematic illustration of one method for visualizing the relationships among classes of characters for an interspecific analysis of the mechanistic bases of behavioral evolution. A: Phylogenetic relationships of five taxa (A to E) with an outgroup taxon (nearest phylogenetic relative) O. B: Principal components analysis of behavioral traits measured, for example, from high-speed video records of movement. Letters indicate the mean for each taxon of values for all the individuals studied in that taxon. Taxa enclosed by a circle are not significantly different from each other. Taxa not enclosed by a circle are significantly different in principal component 1 and 2 scores from all other taxa. C: Principal components analysis of morphological traits measured for the same five taxa. D: Principal components analysis of muscle activity traits. Note the changing pattern of differences among taxa in the different classes of characters. E: Schematic overview of the relationships among the three classes of characters. Lines between adjacent levels connect taxa and show the mapping of character variation; see text for further discussion.

For the same species one might also measure a variety of structural attributes of the musculoskeletal system that are mechanically involved in generating the observed locomotor behavior: e.g., mass of leg muscles and bones, lever arms, or muscle fiber lengths and angles. These data could also be subjected to a PCA (Fig. 2C), and the resulting plot might reveal a different array of taxa in multivariate space. In this schematic example, taxa A and B occupy similar regions of the multivariate morphological space and are similar structurally. These taxa together differ from taxa C, D, and E, all of which occupy distinct morphological positions.

Finally, one might conduct a similar analysis for a set of physiological/functional characters of the limb muscles. For example, study of the pattern of activation (motor pattern) of the limb muscles is of interest in understanding how the nervous system drives limb morphology to generate the locomotor behavior quantified in Fig. 2B. For each species we record the electrical patterns in several limb muscles involved in generating locomotor behavior and quantify such patterns by measuring the duration of electromyographic bursts, peak amplitudes, and relative onset times of activity. These data can then be subjected to a PCA and the position of taxa in the muscle activity pattern space plotted (Fig. 2D). In this schematic example, taxa A, B, and C are similar in motor pattern, while taxa D and E share similar motor patterns to each other and differ from the A, B, and C group.

The most heuristic feature of an analysis of interspecific variation among character classes is evident when we consider the relationships among levels. What is the mapping among taxa from one level to another? When a taxon possesses a novel morphology, does it tend to also possess a novel motor pattern? To what extent are behavioral novelties in a taxon generated by both morphological and neuromuscular changes? Of particular interest is the changing pattern of differences among taxa as we move among levels. This mapping may be visualized simply by orienting the results of each PCA as a plane and connecting taxa with lines (Fig. 2E). The significant feature of this visualization is not changes in absolute locations of each taxon at each level: the positions of each taxon are calculated from a different data matrix at each level, and shifts in absolute position reflect changes in variable correlations within each data set. Rather, it is the changes that occur in groupings of significant differences among taxa that provide

the information of interest. Thus, taxon C possesses a behavior distinct from other members of this clade (Fig. 2E). In addition, this taxon possesses novel features of morphology as compared to outgroup taxa (close relatives) A and B (the phylogeny of this clade is shown in panel A). Taxon C shares a similar motor pattern with taxa A and B. Given a primitively similar motor pattern, a reasonable mechanical/evolutionary hypothesis is that taxon C possesses a derived behavior because of morphological novelties. Taxa A and B share similar motor patterns and morphologies and thus must possess a similar kinematic (behavioral) pattern. Taxa D and E share similar patterns of muscle activation but differ in morphology and behavior. A similar causal evolutionary hypothesis would indicate that the behavioral differences observed between these two taxa result from changes in morphology (such as bone lengths, muscle lever arms and masses) which produce a different behavior given a similar motor pattern.

A variety of theoretically possible patterns of interrelationships among taxa and levels can be envisioned. Figure 3 shows three such patterns in association with the phylogenetic relationships of the five taxa (A to E) and the closest relative of this clade, outgroup taxon O. Figure 3A shows a situation in which there is no general pattern to behavioral, morphological, and motor pattern evolution: each taxon is distinct from the others and possesses derived traits at each level. This pattern is not expected, given the mechanically causal relationships that must exist among levels and our knowledge that many traits are relatively conservative phylogenetically, but it is possible that each taxon could possess autapomorphies (uniquely derived features) for each class of traits.

Figure 3B shows a clade in which all ingroup taxa share a common motor pattern but show interspecific differentiation at the morphological and behavioral levels. In this case, taxa D and E share novelties in morphology that map onto shared behavioral novelties. Variation in morphology is a likely causal explanation of behavioral differentiation among these taxa, since similarities in motor pattern are a plesiomorphic (ancestral) characteristic of the clade and cannot explain behavioral differentiation among taxa. Thus, taxa A, B, and C differ morphologically, and these differences are mirrored by differentiation at the behavioral level.

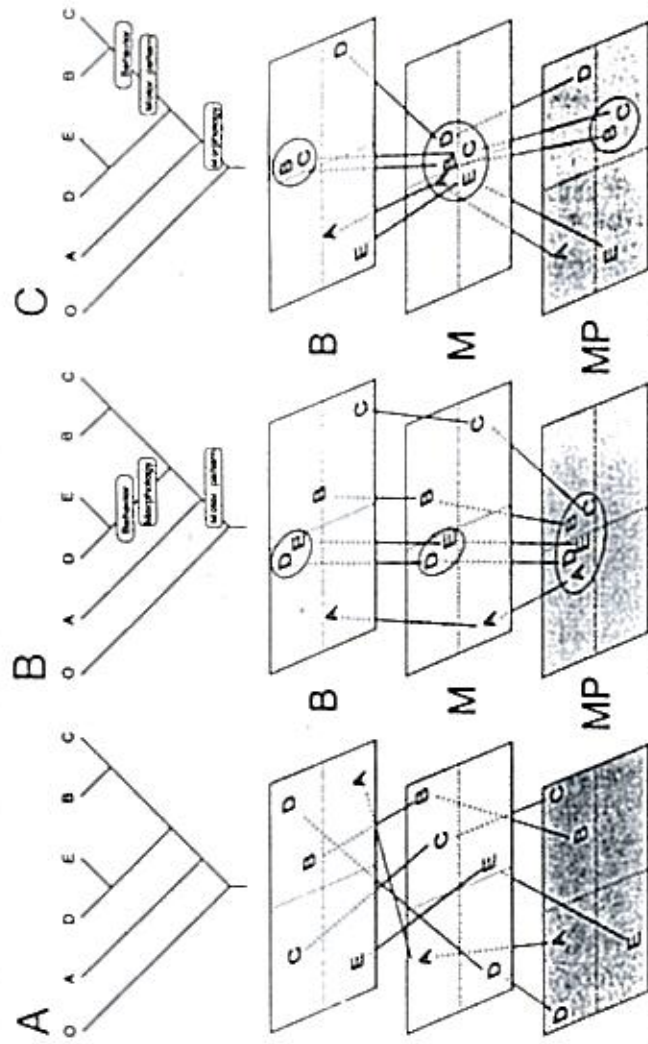

Figure 3. Visualization of three possible patterns of interspecific variation among behavioral, morphological, and motor pattern characters. Each plane represents a plot of principal component 2 (y-axis) versus principal component 1 (x-axis). Conventions for taxa and groupings follow Fig. 2. Phylogenetic interpretations of each pattern are given at the top of each panel. Although other possibilities exist, these three panels show a range of possible results. A: Each taxon possesses uniquely derived (autapomorphic) traits at each level, and there is no clear mapping pattern among levels. B: All five taxa share a common motor pattern. Differentiation at the morphological and behavioral levels is similar. Two taxa (D and E) share common derived morphology and behavior. C: All five taxa share similar morphology, but show divergent motor patterns and behavior. Taxa B and C share novel muscle activity and behavior. Abbreviations: B, Behavioral level; M, morphological level; MP, motor pattern level.

The phylogenetic pattern depicted in Fig. 3B, with taxa showing relatively little differentiation in motor pattern and behavioral differentiation resulting from differences among taxa in morphology, has been the focus of considerable research in the field of functional and evolutionary morphology. A number of authors have suggested that homologous muscles may retain primitive activity patterns, and that behavioral evolution may be a consequence of changes at the morphological level alone Dial et al. 1991; Gatesy 1994; Goslow et al. 1989; Jenkins & Goslow 1983; Lauder 1990; Lauder & Shaffer 1988). Evidence both for and against ontogenetic and phylogenetic conservation of motor patterns has been presented, and as yet no general conclusions are possible (Smith 1994).

Figure 3C illustrates taxa in a clade sharing a similar plesiomorphic (ancestral) morphological configuration, while exhibiting diversity at the motor pattern and kinematic levels. Taxa B and C share derived conditions of both motor output and kinematics (behavior), while taxa A, D, and E possess novel motor patterns and kinematics that are not shared with other taxa.

There are two useful features of such an analysis for understanding causal relationships among the levels deriving from the Newtonian mechanical relationships that connect variation among classes of characters. First, a kinematic differentiation between two taxa that share a common structural plan (e.g., taxa A and E in Fig. 3C) allows the general prediction that A and E must differ in motor pattern. Only by differentiation in motor output could two taxa with similar morphology display different behavior patterns. Second, and more specifically, the individual traits that make up the components can be recovered from the analysis and evaluated against a biomechanical model. Thus, taxon A differs from taxon C in morphology and kinematics (Fig. 3B). An examination of the variables loading highly on morphological PC1 might show that taxon C possesses a longer lower jaw and hyoid linkage in the skull as compared to taxon A. Given the shared ancestral activation pattern of muscles controlling these elements (Fig. 3B), the type of behavioral difference between these taxa can be predicted: a longer time course for mouth movements, for example. This prediction can be checked against the variable loadings for those movements on principal components one and two at the kinematic level.

A case study: aquatic feeding behavior in salamanders

A. Background

The feeding mechanism of salamanders has been the subject of numerous studies over the last 20 years (Cundall 1983; Erdman & Cundall 1984; Larsen et al. 1989; Lauder & Reilly 1990; Lauder & Shaffer 1985, 1988; Lombard & Wake 1976, 1977; Miller & Larsen 1990; Reilly & Lauder 1989a, 1990; Roth 1976; Schwenk & Wake 1993; Thexton et al. 1977; recent reviews in Lauder & Reilly 1994; Lauder & Shaffer 1993; Reilly 1994). These analyses have served to characterize basic biomechanical features of the musculoskeletal system and many aspects of the diversity in salamander skull structure and function. Thus, there is moderately extensive knowledge of behavioral variation, morphology, and muscle function during a behavior that is important to fitness: food acquisition. This background on skull biomechanics facilitates a comparative analysis of feeding behavior (kinematics), morphology of the skull, and motor patterns of cranial musculature that can be used to help analyze patterns of differentiation among taxa in these classes of characters.

Here we present a case study of aquatic feeding behavior in six taxa of salamanders that represent most of the salamander clades exhibiting aquatic prey capture. In this analysis we used our previous functional research on both aquatic and terrestrial prey capture in ambystomatid salamanders (Lauder & Reilly 1988, 1990, 1994; Lauder & Shaffer 1985, 1988; Reilly & Lauder 1988, 1989a, 1989b, 1990; Shaffer & Lauder 1985a, 1985b) to define relevant biomechanical variables at the morphological and motor pattern levels (Table 4.1). The analysis of behavior and morphology has been published elsewhere (Reilly & Lauder 1992), but the electromyographic data on motor patterns used to generate data for the third class of characters (Table 4.1) has not been previously presented. We will demonstrate that interesting historical questions about the evolution of behavior and its underlying physiological bases may emerge from a comparative analysis of different classes of characters that are causally related to the generation of behavior.

B. Methods and data

The six taxa of salamanders used in this analysis are shown in Figure 4 along with their phylogenetic relationships as most recently analyzed by Larson and Dimmick (1993). One difficulty inherent in a comparative analysis involving different salamander families at this time is that current views of the phylogenetic relationships of these families are still the subject of some controversy and ambiguity. We utilized the phylogenetic relationships resulting from a combined analysis of molecular and morphological data sets as summarized by Larson and Dimmick (1993), but other morphological data (which include fossil taxa) support a different topology (Cloutier in press; Trueb & Cloutier

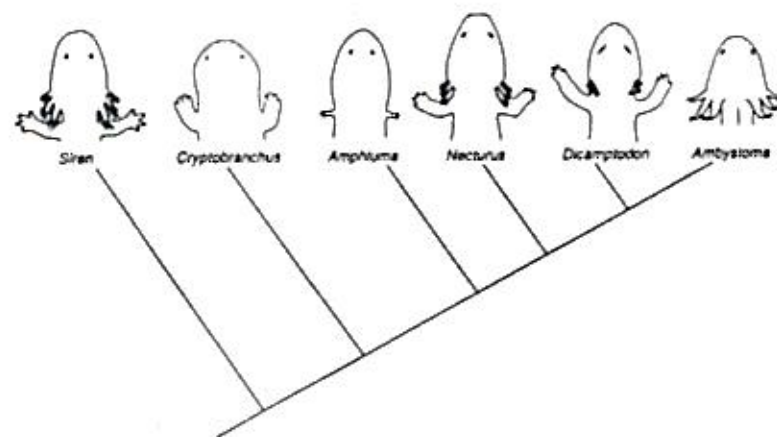

Figure 4. Phylogenetic relationships of the six taxa of salamanders used in this study. Behavioral and morphological data sets were generated for all six taxa, but only four taxa were studied in the analysis of motor patterns (*Siren*, *Cryptobranchus*, *Necturus*, and *Ambystoma*). Phylogenetic relationships of the taxa are from Larson and Dimmick (1993), and the branching pattern reflects only relative time of divergence, not amount of phenotypic change. The external morphology of the head (in dorsal view) is shown for each taxon to illustrate head shape and the size and location of external gill filaments; figures are not drawn to the same scale.

1991). The morphological characters of the feeding mechanism analyzed here are not part of the data used by Larson and Dimmick (1993) and Cloutier (in press) to construct their phylogeny. Prey capture behavior in a total of six families was analyzed: *Siren intermedia* (Sirenidae), *Cryptobranchus allegheniensis* (Cryptobranchidae), *Amphiuma means* (Amphiumidae), *Necturus maculosus* (Proteidae), *Dicamptodon tenebrosus* (Dicamptodontidae), and *Ambystoma mexicanum* (Ambystomatidae). The number of individuals studied varied between 2 and 10 in each species.

Prey capture in salamanders is rapid (taking between 30 and 120 ms), requiring high-speed films or video recordings (at 200 frames per second) for accurate measurement of cranial bone movements. Individual salamanders were trained to feed in an aquarium under filming lights, and 1- to 2-cm-long pieces of earthworms (*Lumbricus*) were used as prey. Video or film recordings of prey capture were analyzed frame by frame to quantify head movements. From each frame we digitized movements of the head, hyoid region, and jaws. Profiles of the movements of each set of structures were plotted against time (a sample kinematic profile for *Necturus* is shown in Figure 5) and from these profiles seven kinematic variables were derived that describe the behavior of the head during feeding. Behavioral variables measured both the timing of movement (such as the time to maximal head angle and the duration of the gape cycle from the onset of mouth opening to mouth closing) and the amplitude of bone movement. At least five feedings were quantified from each individual.

Cranial morphology of the six taxa was characterized by measuring five structural variables that described features of head shape relevant to prey capture behavior. Morphological variables included the number of open gill slits at the back of the buccal cavity (a hydrodynamically important factor in the feeding mechanism, Lauder & Shaffer 1986; Reilly & Lauder 1988), and measurements of lower jaw length and head size.

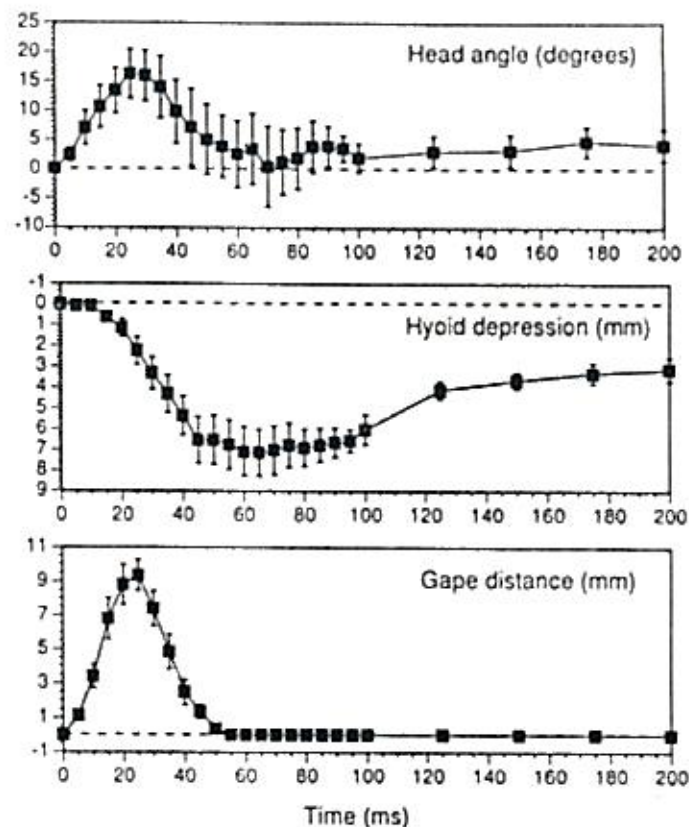

Figure 5. Sample kinematic plots of head movements during prey capture by *Necturus*. Points shown are means ($N=5$) from one individual with the standard error about the mean. Head angle increases from 0 to 25 ms indicating elevation of the skull on the vertebral column. Peak gape is also reached at 25 ms, while hyoid depression (reflecting expansion of the throat) begins a plateau at 45 ms. Prey capture occurs within 50 ms. Plots from individual feedings such as this were used to generate the behavioral variables for the principal components analysis.

Motor output to the cranial musculature was measured by implanting fine-wire electrodes into five muscles involved in generating

movements of the head, jaws, and hyoid during prey capture. These muscles were chosen to reflect likely causal relationships between morphology and feeding behavior. For example, head angle was one of the kinematic variables measured, and the epaxial muscles are the only set of muscles in the head capable of generating an increase in head angle; thus, activity in the epaxial musculature was quantified. Individual salamanders were anaesthetized and electrodes implanted percutaneously into cranial muscles as in previous research (Lauder & Shaffer 1985; Reilly & Lauder 1991). The five homologous muscles studied in each taxon were (a) the epaxial muscles, which act to elevate the head and thus contribute to opening the mouth during feeding; (b) the depressor mandibulae muscle, which acts to move the lower jaw ventrally and thus open the mouth; (c) the rectus cervicis muscle, which moves the hyoid apparatus posteroventrally expanding the volume inside the mouth cavity and creating suction; (d) the adductor mandibulae externus muscle, which is one of two major mouth closing muscles; (e) the branchiohyoideus muscle, which acts to abduct the gill arches during prey capture [Lauder and Shaffer (1985) provide morphological descriptions of these muscles in *Ambystoma*]. *Cryptobranchus* possesses the capability of generating asymmetrical movements of the right and left sides of the head during feeding (Cundall et al. 1987), and we implanted bilateral electrodes (for a total of 10 channels) to assess asymmetry in one individual. Electrodes from each muscle were bundled together into a common cable that led from an attachment on the animal's back to AC preamplifiers (amplification was $5000\times$ to $10,000\times$) and then into an FM tape recorder. All channels were recorded simultaneously. The analog tape recordings of electromyographic data were digitized at 12-bit resolution (8000-Hz sample rate) into a binary data file from which individual motor pattern variables were measured (to the nearest 0.1 ms resolution). Due to limited animal availability and performance with implanted electrodes, electromyographic data could be obtained from only four taxa: *Siren*, *Cryptobranchus*, *Necturus*, and *Ambystoma*.

Electromyographic data from a single prey capture event by *Cryptobranchus* are shown in Fig. 6. Most muscles show a rapid onset of activity (within 10 ms of each other) except for the adductor mandibulae, which occasionally showed a considerable delay in onset. From these data, 14 motor pattern variables were measured. The onset

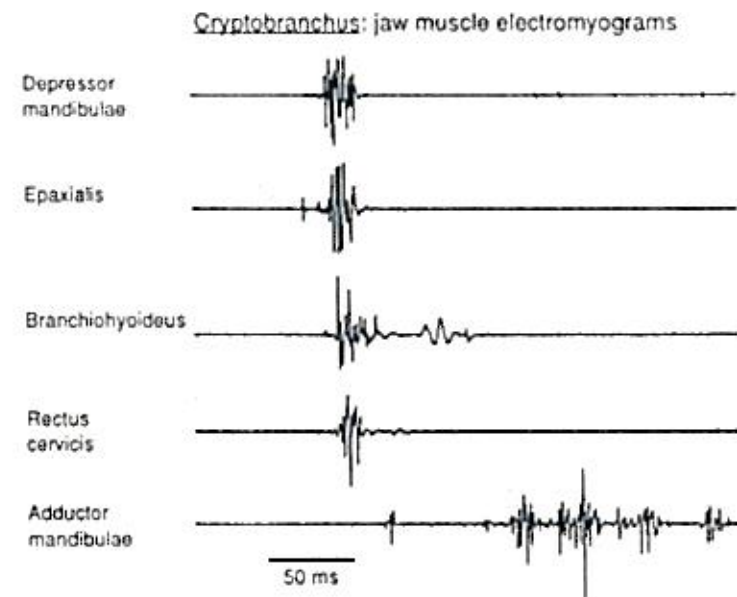

Figure 6. Representative pattern of muscle activity for five cranial muscles during prey capture by *Cryptobranchus*. Note the nearly simultaneous onset time in all muscles except for the adductor mandibulae. Recordings such as this were used to generate the motor pattern variables for the principal components analysis.

of activity in four muscles was measured relative to the onset time of the rectus cervicis muscle. The rectus cervicis is a major mouth-opening muscle, often used as a marker of the onset of the feeding motor pattern. We measured the duration of each muscle burst and the total rectified integrated electrical activity within each burst.

Separate statistical analyses on the three data sets (behavioral, morphological, and motor pattern) included standard two-level nested analysis of variance (with individuals nested within taxon), PCA on the correlation matrix of each data set (since variables differed in measurement scale; Bookstein et al. 1985), and multivariate analysis of variance on the principal component scores to define groups of taxa within each class of data.

C. Results and interpretation

Results from the analysis of three classes of data for the four taxa common to all three levels are presented in Fig. 7. This figure schematically represents three plots of principal components one (horizontal or x axis) and two (y axis) resulting from analyses of the three separate data sets. The first two levels represent a subset of the behavioral and morphological results presented by Reilly and Lauder (1992) for all six taxa. Each taxon is represented by a letter reflecting the mean position of the values for all individuals measured in that taxon, and taxa that are not significantly different from each other are grouped by circles. Taxa that are not located within a circle are significantly different from other groupings within each level when all characters are considered together.

Behaviorally, *Ambystoma* and *Necturus* share common features of prey capture movements that result in both taxa grouping together in the principal components analysis of feeding behavior (Fig. 7). *Siren* and *Cryptobranchus* are located in different regions of the multivariate space that describes prey capture and are distinct both from each other and from the *Ambystoma* + *Necturus* group. High values of principal component 1 reflect larger values for maximal mouth opening and hyoid expansion, while larger values of principal component 2 indicate more rapid feedings (shorter gape cycle times and time to maximal gape). Thus, *Cryptobranchus* possesses slower prey capture and larger mouth and hyoid excursions than the other taxa. Morphologically, *Siren* and *Ambystoma* possess similar cranial structures (Fig. 7), while *Necturus* and *Cryptobranchus* occupy divergent areas of morphological space.

Mappings between the behavioral and morphological levels reveal several interesting patterns, and this visualization facilitates consideration of the extent to which behavioral variation among taxa may be due to changes in morphology. First, taxa such as *Ambystoma* and *Siren*, which share similar morphology, show divergent behavior. This result must be due to differences between these two taxa at the motor pattern level. The mapping between the behavioral and morphological levels can thus be used to predict patterns of variation in motor pattern. Second, since *Ambystoma* and *Necturus* are divergent in morphology but not in behavior, one cannot predict the pattern of interspecific variation in motor pattern. Morphological variation alone

could cause behavioral differences, as could differences in both morphology and motor pattern. A similar result obtains for the mappings between levels for *Cryptobranchus*. Third, taxa may show similar behavior and divergent morphologies, or the converse. No overall pattern corresponding to the examples in Fig. 3 was found.

Examination of the motor pattern data for the four taxa (Fig. 7) shows that *Necturus* and *Cryptobranchus* share similar regions of motor pattern space, while *Ambystoma* and *Siren* are divergent. High values on principal component 1 primarily reflect greater activity (longer duration and higher rectified integrated area) for the rectus cervicis muscle, longer duration activity in the branchiohyoideus and epaxial muscles, and shorter relative onset times of the depressor mandibulae and epaxial muscles. High values of principal component 2 indicate greater activity in the depressor mandibulae and adductor mandibulae muscles and longer relative onset times of the depressor mandibulae and epaxial muscles. Thus, compared to *Siren*, the motor pattern used by *Ambystoma* during prey capture involves relatively less activity in the rectus cervicis and longer times between rectus cervicis onset and the start of activity in the depressor and adductor mandibulae muscles.

Overall, the mappings among the three levels demonstrate three significant patterns. First, two of the taxa, *Ambystoma* and *Necturus*, possess divergent motor patterns and morphology but share similar prey capture behavior patterns. These two taxa have taken different mechanistic "paths" to arrive at a similar behavioral phenotype; differences in motor pattern and morphology are interacting to generate similar bone movements. Second, the prediction discussed above (based on the analysis of data from the behavioral and morphological levels), that *Ambystoma* and *Siren* must show divergent motor patterns is correct. These two taxa show significantly different patterns of muscle activity. Causally, differences at the motor pattern level must account for differences at the behavioral level. Third, *Cryptobranchus*, is distinct in morphology and behavior but possesses a similar motor pattern to *Necturus*. This result indicates that morphological and behavioral divergence in *Cryptobranchus* is not mirrored at the motor pattern level. Overall, the relationships observed among taxa and levels in this study are complex, and no general patterns are apparent.

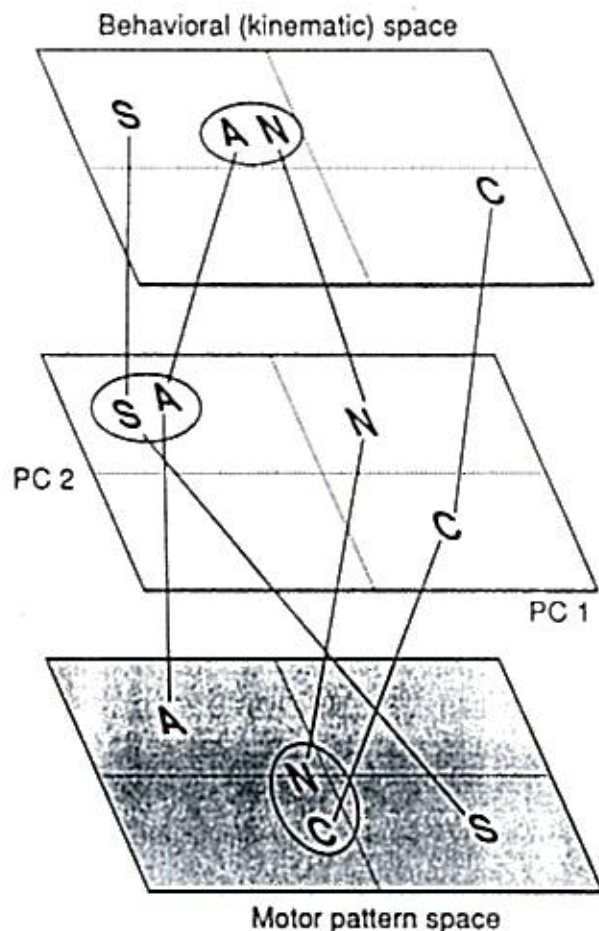

Figure 7. Results from the principal components analysis of three data sets: behavioral, at the top; morphological, in the middle; motor pattern, at bottom. Each plane represents principal component 2 (PC2) plotted against principal component 1 (PC1). Following the conventions established in Figure 2, lines connect taxa on adjacent planes, while taxa that are not significantly different from each other are circled. Abbreviations: A, *Ambystoma*; C, *Cryptobranchus*; N, *Necturus*; S, *Siren*.

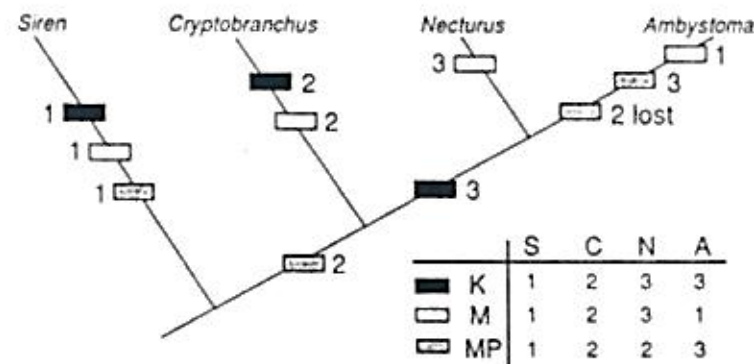

Figure 8. Phylogenetic interpretation of the changes in traits at each of three levels: K, kinematic (behavioral), M, morphological, and MP, motor pattern. The data matrix in the lower right codes the differences among taxa for each class of characters based on the results of statistical tests on principal component 1 and 2 scores. Taxa with the same numbered state are not significantly different from each other in this trait. The resulting characters in the data matrix are mapped onto the phylogeny. Note that motor pattern character state 2 is illustrated as having been gained once and then lost in *Ambystoma*. An equally parsimonious explanation of this character is that it was gained independently in *Cryptobranchus* and *Necturus*.

The data shown in Fig. 7 may also be analyzed phylogenetically as discrete character states. In Fig. 8 the variation among the four taxa for each of the three classes of characters is coded into discrete states (1, 2, or 3) based on statistical differences among taxa at each level. For example, at the kinematic level (K), *Necturus* and *Ambystoma* are coded as state 3 based on similar patterns of bone movement, while the other two taxa receive character state codes of 1 and 2. Perhaps the most striking feature of the phylogenetic pattern depicted in Fig. 8 is the extent to which the four taxa possess uniquely derived (autapomorphic) features of behavior, morphology, and motor pattern: there has been

considerable phylogenetic divergence in all three classes of characters. Only one character (the shared kinematic pattern of *Necturus* and *Ambystoma*, coded 3) can be used to unambiguously diagnose a monophyletic clade. A second character, the motor pattern shared by *Necturus* and *Cryptobranchus* (coded 2) could diagnose the *Cryptobranchus+Necturus+Ambystoma* clade (with a loss of this character in *Ambystoma*). Alternatively, this character could have arisen independently in *Cryptobranchus* and *Necturus*.

General discussion

The method presented here for visualizing differences among taxa in behavior focuses on the mechanical interrelationships among bone movement (behavior), morphology, and output from the central nervous system. But not all interspecific differences in behavior are the result of changes at these levels. Learned behavior patterns, for example, do not result from changes in morphology (although learning may change motor output; Wainwright 1986). Differences among taxa in biochemistry or in organismal properties not addressed by the levels in Table 4.1 may also contribute to interspecific behavioral differentiation. Furthermore, changes in behavior may have arisen phylogenetically prior to changes in morphology. Indeed, there has been considerable discussion in past ethological literature as to the primacy of morphological or behavioral change (Lauder 1986). The visualization presented in Fig. 2 suggests that changes in behavior are due (and caused by) changes in morphology or motor pattern, and thus that behavioral changes occur either along the same branch or at a later time phylogenetically than changes in morphology. A phylogenetic analysis of behavioral and morphological characters might show that a change in behavior preceded the occurrence of novel morphology, thus changing the direction of causality implied by Fig. 2. In such cases, the analysis of characters at the motor pattern level is critical, as alterations in motor pattern may well have caused behavioral change prior to alterations in musculoskeletal structure. For example, neuromodulators within the nervous system may change and produce novel behavior in a species without any change in peripheral morphology. Neuromodulators can alter motor output directly by their effect on central neurons and thus generate a novel behavior (Katz 1991 discusses examples). Change in

neuromodulators and the consequent change in behavior may then characterize a clade which is similar in morphology. This scenario would produce a pattern similar to that shown in Fig. 3C.

Answering the question "Which changes first, morphology or behavior?" depends on (1) a phylogenetic analysis of morphological and behavioral characters and (2) an assessment of motor patterns produced by the nervous system. We predict that when phylogenetic analysis demonstrates novelties in behavior preceding morphology, motor output from the nervous system will be found to have changed concordantly with behavior, and novelties in both these classes of characters will precede morphology.

Although we believe that there is much to be gained by the comparative mechanistic analysis of interspecific differences in behavior, this is one aspect of ethology that has received relatively little attention. Compared to progress that has been recently made in the comparative (phylogenetic) study of behavioral ecology (e.g., Brooks & McLennan 1991; Harvey & Pagel 1991; Harvey et al. 1990), our knowledge of behavioral, structural, and functional variation among taxa is minimal. In discussing the method of analyzing interspecific behavioral differentiation presented here, we will first consider practical issues that bear on the development of case studies, then discuss analytical considerations, and finally address strengths of this approach. There are a number of reasons why comparative functional data are relatively scarce. Obtaining both physiological and morphological data on a variety of taxa is extremely time consuming, particularly if complex physiological procedures must be performed on multiple individuals within each taxon. Measuring physiological traits in living animals often requires a number of invasive experimental techniques. This may limit the size range of animals that can be studied, restricting comparative functional data to those taxa in which adults are a suitable size. In addition, species vary in their ability to tolerate experimental procedures while still exhibiting normal behavioral responses. Some species simply do not respond well to laboratory conditions, and yet such species may be critical for testing a given comparative hypothesis. Unless physiological data can be obtained along with behavioral characters, we will not be able to make the link between functional and behavioral variation. Of course, the ability to obtain functional data

depends critically on the availability of species in the chosen clade in the first place. While structural data may be obtained from museum specimens, physiological and behavioral data clearly cannot. In this study we began with a behavioral and morphological analysis of six taxa (Fig. 4; Reilly & Lauder 1992), but data on muscle activity patterns could be obtained for just four taxa.

A significant problem may arise when taxa studied are reduced to a small number. With such a small number of taxa, the opportunity for finding cases of convergent character acquisition (which may themselves provide tests of causal hypotheses) is small, and the possibility of conducting statistical tests of character association greatly reduced. The availability of a small number of taxa within a larger clade also increases the possibility of identifying some traits as uniquely derived characters of a single taxon (autapomorphies) when in reality these traits might characterize a larger grouping of taxa.

The conventional approach to analyzing traits of this kind has been to map characters onto a phylogeny of the studied taxa (e.g., Lauder 1990; Brooks & McLennan 1991; Maddison & Maddison 1992). Such mappings allow the sequential acquisition of characters in a clade to be determined. Given a sufficiently large number of taxa and a well-corroborated phylogeny, relationships among characters can be assessed by using quantitative phylogenetic techniques for the analysis of correlated characters (e.g., Pagel 1994). But if the number of taxa is small, then, as is evident from the character mappings presented in Fig. 8, relatively few novel insights are gained into the data using a mapping type of analysis. On the other hand, when the number of character classes equals or exceeds three and the number of taxa is also large, simply gaining a basic understanding of the pattern of variation among characters can be difficult.

One of the reasons for presenting the multivariate visualization illustrated in this paper is that it facilitates analysis of variation among several taxa as well as among multiple classes of characters simultaneously. But as yet there are no analytical techniques that have been applied to data such as those presented here which would allow a quantitative assessment of mapping among levels. A significant advance would be the direct incorporation of information on the phylogenetic history of the taxa into the analysis of the mappings themselves. Use of phylogenetically standardized contrasts (based on a well-corroborated

phylogeny) at each level as data for the principal components analysis (Felsenstein 1985; Martins 1993) would incorporate information on phylogeny into each plane of Fig. 2, but would not resolve the problem of analyzing mappings among levels. Path analytic techniques might provide a partial solution to this problem, as might analyses of data matrices for each class of characters as suggested by Douglas and Endler (1982). Alternatively, the statistical relationships among taxa at each level could be transformed into alternative hypotheses for phylogenetic relationships among taxa. Each class of characters provides evidence of genealogical relationships among taxa, and these cladograms (one for each class of characters) could be examined for regions of congruence and incongruence.

There are considerable benefits to be gained from a comparative analysis of structural and functional traits that underlie behavioral variation among taxa. Comparative analyses are needed to provide proximate explanations of behavioral differentiation, and such explanations are critical for a comprehensive understanding of behavioral evolution. We present this study as an example of one simple approach to visualizing the relationships among both taxa and classes of characters that underlie behavioral diversification. By considering the causal bases of behavioral differentiation among taxa as consisting of several different classes of characters (Table 4.1), we are able to hypothesize how behavior and its underlying mechanistic bases have evolved. Is there congruence in patterns of variation among types of characters? Does the existence of behavioral novelties in a clade necessarily imply novelties at both the morphological and motor pattern levels? Do motor pattern and behavioral characters tend to coevolve prior to morphological differentiation? Such questions may be approached, at least to a first approximation, by describing the variation within each class of characters using principal components analysis, and then considering the taxonomic mappings among levels.

One advantage of this approach is the generation of an understandable scheme for visualizing both the changing relationships among characters as well as among classes of traits. Figure 7, for example, reduces a considerable amount of information into a manageable format which highlights key changes across levels. As a visualization and description of the data, such figures point to areas

where further investigation would be profitable (such as a detailed study of the comparative feeding biomechanics of *Ambystoma* and *Necturus*). In addition, there is a predictive aspect to such visualizations that extends the approach beyond the merely descriptive. For example, analysis of behavior and morphology in salamander feeding mechanisms led Reilly and Lauder (1992) to make several predictions about results at the motor pattern level prior to collecting the muscle activity data for this chapter. A prediction was made that *Cryptobranchus* and *Siren* would likely possess significantly different motor patterns, as should *Siren* and *Ambystoma*. Because of the mechanically causal relationships among levels, differences in behavior possessed by taxa that are similar in morphology must be generated by differences in muscle activity. The motor pattern data gathered for this study confirm both predictions.

Although the approach described here is but one avenue by which the analysis of behavioral evolution might proceed, in conjunction with other research directions and an increased focus on the evolution of physiological and functional traits in general (Garland & Carter 1994; Huey 1987; Huey & Bennett 1987; Lauder 1991a, b, 1994; Wainwright & Reilly 1994), we are likely to see much new information over the next few years on the evolution of the mechanistic bases of animal behavior.

ACKNOWLEDGMENTS

We thank Emilia Martins, Al Bennett, Ted Garland, Don Miles, Julian Humphries, John Endler, Barry Chernoff, Dick Hudson, and Steve Frank for helpful discussions concerning the data and concepts in this paper. Two anonymous reviewers provided many helpful comments. This research was supported by NSF IBN 91-19502 to GVL, and Ohio University Research Challenge Grant RC94-028 to SMR.

References

- Arbas, E. A., I. A. Meinertzhagen, & S. R. Shaw. 1991. Evolution in nervous systems. *Annu. Rev. Neurosci.*, 14, 9-38.
- Bookstein, F., B. Chernoff, R. Elder, J. Humphries, G. Smith, & R. Strauss. 1985. *Morphometrics in Evolutionary Biology*. Philadelphia: Academy of Natural Sciences.

- Bray, J. H., & S. E. Maxwell. 1985. *Multivariate Analysis of Variance*. Beverly Hills, California: Sage Publications.
- Brooks, D. R., & D. A. McLennan. 1991. *Phylogeny, Ecology and Behavior*. Chicago: University of Chicago Press.
- Brooks, D. R., & D. A. McLennan. 1993. *Parascript. Parasites and the Language of Evolution*. Washington, D. C.: Smithsonian Institution Press.
- Cloutier, R. (in press). Phylogenetic status, basal taxa, and interrelationships of lower sarcopterygian groups. *Zool. J. Linn. Soc. Lond.*
- Cundall, D. 1983. Activity of head muscles during feeding by snakes: A comparative study. *Am. Zool.*, 23, 383-396.
- Cundall, D., J. Lorenz-Elwood, & J. D. Groves. 1987. Asymmetric suction feeding in primitive salamanders. *Experientia*, 43, 1229-1231.
- Dial, K. P., G. E. Goslow, & F. A. Jenkins. 1991. The functional anatomy of the shoulder in the European starling (*Sturnus vulgaris*). *J. Morphol.*, 207, 327-344.
- Douglas, M. E., & J. A. Endler. 1982. Quantitative matrix comparisons in ecological and evolutionary investigations. *J. Theor. Biol.*, 99, 777-795.
- Duntleman, G. H. 1989. *Principal Components Analysis*. Newbury Park, California: Sage Publications.
- Erdman, S., & D. Cundall. 1984. The feeding apparatus of the salamander *Amphiuma tridactylum*: morphology and behavior. *J. Morphol.*, 181, 175-204.
- Felsenstein, J. 1985. Phylogenies and the comparative method. *Am. Nat.*, 125, 1-15.
- Garland, T., & S. C. Adolph. 1994. Why not to do 2-species comparisons: Limitations on inferring adaptation. *Physiol. Zool.*, 67, 797-828.
- Garland, T., & P. A. Carter. 1994. Evolutionary physiology. *Annu. Rev. Physiol.*, 56, 579-621.
- Garland, T., A. W. Dickerman, C. M. Janis, & J. A. Jones. 1993. Phylogenetic analysis of covariance by computer simulation. *Syst. Biol.*, 42, 265-292.
- Garland, T., P. H. Harvey, & A. R. Ives. 1992. Procedures for the analysis of comparative data using phylogenetically independent contrasts. *Syst. Biol.*, 41, 18-32.
- Gatesy, S. M. 1994. Neuromuscular diversity in archosaur deep dorsal thigh muscles. *Brain Behav. Evol.*, 43, 1-14.
- Goslow, G. E., K. P. Dial, & F. A. Jenkins. 1989. The avian shoulder: an experimental approach. *Am. Zool.*, 29, 287-301.
- Grafen, A. 1989. Phylogenetic regression. *Phil. Trans. R. Soc. Lond., Series B.*, 326, 119-157.
- Harris, R. J. 1975. *A Primer of Multivariate Statistics*. New York: Academic Press.
- Harvey, P. H., & A. E. Keymer. 1991. Comparing life histories using phylogenies. *Phil. Trans. R. Soc. Lond., Series B.*, 332, 31-39.
- Harvey, P. H., & M. D. Pagel. 1991. *The Comparative Method in Evolutionary Biology*. Oxford, England: Oxford University Press.
- Harvey, P. H., A. F. Read, & D. E. Promislow. 1990. Life history variation in placental mammals: unifying the data with theory. *Oxford Surv. Evol. Biol.*, 6, 13-31.

- Hoy, R. R., A. Hoikkala, & K. Kaneshiro. 1988. Hawaiian courtship songs: Evolutionary innovation in communication signals of *Drosophila*. *Science*, 240, 217-219.
- Huey, R. 1987. Phylogeny, history, and the comparative method. In: *New Directions in Ecological Physiology* (Ed. by M. Feder, A. F. Bennett, W. W. Burggren, and R. B. Huey), pp. 76-101. Cambridge, England: Cambridge University Press.
- Huey, R. B., & A. F. Bennett 1987. Phylogenetic studies of coadaptation: preferred temperature versus optimal performance temperature of lizards. *Evolution*, 41, 1098-1115.
- Jenkins, F. A., & G. E. Goslow. 1983. The functional anatomy of the shoulder of the Savannah Monitor Lizard (*Varanus exanthematicus*). *J. Morphol.*, 175, 195-216.
- Katz, P. S. 1991. Neuromodulation and the evolution of a simple motor system. *Semin. Neurosci.*, 3, 379-389.
- Katz, P. S., & K. Tazaki. 1992. Comparative and evolutionary aspects of the crustacean stomatogastric system. In: *Dynamic Biological Networks: The Stomatogastric Nervous System* (Ed. by R. M. Harris-Warrick, E. Marder, A. I. Selverston, & M. Moulins), pp. 221-261. Cambridge, Massachusetts: MIT Press.
- Larsen, J. H., J. T. Beneski, & D. B. Wake. 1989. Hyolingual feeding systems of the Plethodontidae: Comparative prey capture kinematics of free projectile, attached projectile and protrusible tongued salamanders. *J. Exp. Zool.*, 252, 25-33.
- Larson, A., & W. W. Dimmick. 1993. Phylogenetic relationships of the salamander families: An analysis of congruence among morphological and molecular characters. *Herpetol. Monogr.*, 7, 77-93.
- Lauder, G. V. 1986. Homology, analogy, and the evolution of behavior. In: *The Evolution of Behavior* (Ed. by M. Nitecki, & J. Kitchell), pp. 9-40. Oxford, England: Oxford University Press.
- Lauder, G. V. 1990. Functional morphology and systematics: studying functional patterns in an historical context. *Annu. Rev. Ecol. Syst.*, 21, 317-340.
- Lauder, G. V. 1991a. Biomechanics and evolution: integrating physical and historical biology in the study of complex systems. In: *Biomechanics in Evolution* (Ed. by J. M. V. Rayner, & R. J. Wootton), pp. 1-19. Cambridge, England: Cambridge University Press.
- Lauder, G. V. 1991b. An evolutionary perspective on the concept of efficiency: How does function evolve? In: *Efficiency and Economy in Animal Physiology* (Ed. by R. W. Blake), pp. 169-184. Cambridge, England: Cambridge University Press.
- Lauder, G. V. 1994. Homology, form, and function. In: *Homology: The Hierarchical Basis of Comparative Biology* (Ed. by B. K. Hall), pp. 151-196. San Diego, California: Academic Press.
- Lauder, G. V. 1995. On the inference of function from structure. In: *Functional Morphology in Vertebrate Paleontology* (Ed. by J. Thomason), pp. 1-18. Cambridge, England: Cambridge University Press.
- Lauder, G. V., & S. M. Reilly. 1988. Functional design of the feeding mechanism in salamanders: causal bases of ontogenetic changes in function. *J. Exp. Biol.*, 134, 219-233.
- Lauder, G. V., & S. M. Reilly. 1990. Metamorphosis of the feeding mechanism in tiger salamanders (*Ambystoma tigrinum*): the ontogeny of cranial muscle mass. *J. Zool.*, 222, 59-74.
- Lauder, G. V., & S. M. Reilly. 1994. Amphibian feeding behavior: comparative biomechanics and evolution. In: *Advances in Comparative and Environmental Physiology: Biomechanics of Feeding in Vertebrates* (Ed. by V. L. Bels, M. Chardon, & P. Vandewalle), pp. 163-195. Berlin: Springer-Verlag.
- Lauder, G. V., & H. B. Shaffer. 1985. Functional morphology of the feeding mechanism in aquatic ambystomatid salamanders. *J. Morphol.*, 185, 297-326.
- Lauder, G. V., & H. B. Shaffer. 1986. Functional design of the feeding mechanism in lower vertebrates: Unidirectional and bidirectional flow systems in the tiger salamander. *Zool. J. Linn. Soc. Lond.*, 88, 277-290.
- Lauder, G. V., & H. B. Shaffer. 1988. The ontogeny of functional design in tiger salamanders (*Ambystoma tigrinum*): Are motor patterns conserved during major morphological transformations? *J. Morphol.*, 197, 249-268.
- Lauder, G. V., & H. B. Shaffer. 1993. Design of feeding systems in aquatic vertebrates: Major patterns and their evolutionary interpretations. In: *The Skull*, Vol. 3: *Functional and Evolutionary Mechanisms* (Ed. by J. Haaken and B. K. Hall), pp. 113-149. Chicago: University of Chicago Press.
- Lombard, R. E., & D. B. Wake. 1976. Tongue evolution in the lungless salamanders, family Plethodontidae: I. Introduction, theory, and a general model of dynamics. *J. Morphol.*, 148, 265-286.
- Lombard, R. E., & D. B. Wake. 1977. Tongue evolution in the lungless salamanders, family Plethodontidae: II. Function and evolutionary diversity. *J. Morphol.*, 153, 39-80.
- Maddison, W. P., & D. R. Maddison. 1992. *MacClade Version 3: Analysis of Phylogeny and Character Evolution*. Sunderland, Massachusetts: Sinauer and Associates.
- Martins, E. P. 1993. A comparative study of the evolution of *Sceloporus* push-up displays. *Am. Nat.*, 142, 994-1018.
- Martins, E. P., & T. Garland, Jr. 1991. Phylogenetic analysis of the correlated evolution of continuous characters: A simulation study. *Evolution*, 45, 534-557.
- McLennan, D. A., D. R. Brooks, & J. D. McPhail. 1988. The benefit of communication between comparative ethology and phylogenetic systematics: A case study using gasterosteid fishes. *Can. J. Zool.*, 66, 2177-2190.
- Miles, D. B., & A. E. Dunham. 1993. Historical perspectives in ecology and evolutionary biology: The use of phylogenetic comparative analyses. *Ann. Rev. Ecol. Syst.*, 24, 587-619.
- Miller, B. T., & J. H. Larsen. 1990. Comparative kinematics of terrestrial prey capture in salamanders and newts (Amphibia: Urodela: Salamandridae). *J. Exp. Zool.*, 256, 135-153.
- Mitter, C., B. Farrell, & D. J. Futuyma. 1991. Phylogenetic studies of insect-plant interactions: insights into the genesis of diversity. *TREE*, 6, 290-293.

- Pagel, M. 1994. Detecting correlated evolution on phylogenies: a general method for the comparative analysis of discrete characters. *Proc. R. Soc. Lond., Series B*, 255, 37-45.
- Pagel, M. D., & P. H. Harvey. 1988. How mammals produce large-brained offspring. *Evolution*, 42, 948-957.
- Reilly, S. M. 1994. The ecological morphology of metamorphosis: heterochrony and the evolution of feeding mechanisms in salamanders. In: *Ecological Morphology: Integrative Organismal Biology* (Ed. by P. C. Wainwright, & S. M. Reilly), pp. 319-338. Chicago: University of Chicago Press.
- Reilly, S. M., & G. V. Lauder. 1988. Ontogeny of aquatic feeding performance in the eastern newt *Notophthalmus viridescens* (Salamandridae). *Copeia*, 1988, 87-91.
- Reilly, S. M., & G. V. Lauder. 1989a. Kinetics of tongue projection in *Ambystoma tigrinum*: quantitative kinematics, muscle function, and evolutionary hypotheses. *J. Morphol.*, 199, 223-243.
- Reilly, S. M., & G. V. Lauder. 1989b. Physiological bases of feeding behavior in salamanders: do motor patterns vary with prey type? *J. Exp. Biol.*, 141, 343-358.
- Reilly, S. M., & G. V. Lauder. 1990. The strike of the tiger salamander: quantitative electromyography and muscle function during prey capture. *J. Comp. Physiol.*, 167, 827-839.
- Reilly, S. M., & G. V. Lauder. 1991. Experimental morphology of the feeding mechanism in salamanders. *J. Morphol.*, 210, 33-44.
- Reilly, S. M., & G. V. Lauder. 1992. Morphology, behavior, and evolution: comparative kinematics of aquatic feeding in salamanders. *Brain Behav. Evol.*, 40, 182-196.
- Reilly, S. M., & P. C. Wainwright. 1994. Ecological morphology and the power of integration. In: *Ecological Morphology: Integrative Organismal Biology* (Ed. by P. C. Wainwright, & S. M. Reilly), pp. 339-354. Chicago: University of Chicago Press.
- Rohlf, F. J., & F. L. Bookstein, editors. 1990. *Proceedings of the Michigan Morphometrics Workshop*. Ann Arbor: University of Michigan Museum of Zoology.
- Roth, G. 1976. Experimental analysis of the prey catching behavior of *Hydromantes italicus* Dunn (Amphibia, Plethodontidae). *J. Comp. Physiol.*, 109, 47-58.
- Ryan, M. J., & A. Keddyhector. 1992. Directional patterns of female mate choice and the role of sensory biases. *Am. Nat.*, 139(S), S4-S35.
- Ryan, M. J., & A. S. Rand. 1990. The sensory basis of sexual selection for complex calls in the Tungara frog, *Physalaemus pustulosus* (sexual selection for sensory exploitation). *Evol.*, 44(2), 305-314.
- Schwenk, K., & D. B. Wake. 1993. Prey processing in *Leurognathus marmoratus* and the evolution of form and function in desmognathine salamanders (Plethodontidae). *Biol. J. Linn. Soc.*, 49, 141-162.
- Shaffer, H. B., & G. V. Lauder. 1985a. Aquatic prey capture in ambystomatid salamanders: patterns of variation in muscle activity. *J. Morphol.*, 183, 273-326.
- Shaffer, H. B., & G. V. Lauder. 1985b. Patterns of variation in aquatic ambystomatid salamanders: kinematics of the feeding mechanism. *Evol.*, 39, 83-92.
- Smith, K. K. 1994. Are neuromotor systems conserved in evolution? *Brain Behav. Evol.*, 43, 293-305.
- Thexton, A. J., D. B. Wake, & M. H. Wake. 1977. Tongue function in the salamander *Bolitoglossa occidentalis*. *Arch. Oral Biol.*, 22, 361-366.
- Trueb, L., & R. Cloutier. 1991. A phylogenetic investigation of the inter- and intrarelationships of the Lissamphibia (Amphibia: Temnospondyli). In: *Origins of the Higher Groups of Tetrapods: Controversy and Consensus* (Ed. by H.-P. Schultze, & L. Trueb), pp. 223-313. Ithaca, New York: Comstock Publishing Associates.
- Wainwright, P. C. 1986. Motor correlates of learning behavior: feeding on novel prey by the pumpkinseed sunfish (*Lepomis gibbosus*). *J. Exp. Biol.*, 126, 237-247.
- Wainwright, P. C., & S. M. Reilly, editors. 1994. *Ecological Morphology: Integrative Organismal Biology*. Chicago: University of Chicago Press.
- Willig, M. R., R. D. Owen, & R. L. Colbert. 1986. Assessment of morphometric variation in natural populations: the inadequacy of the univariate approach. *Syst. Zool.*, 35, 195-203.